

## DATI TECNICI-TECHNICAL FEATURES- CARACTERISTIQUES TECHNIQUES-TEKNISCHE MERKMALE

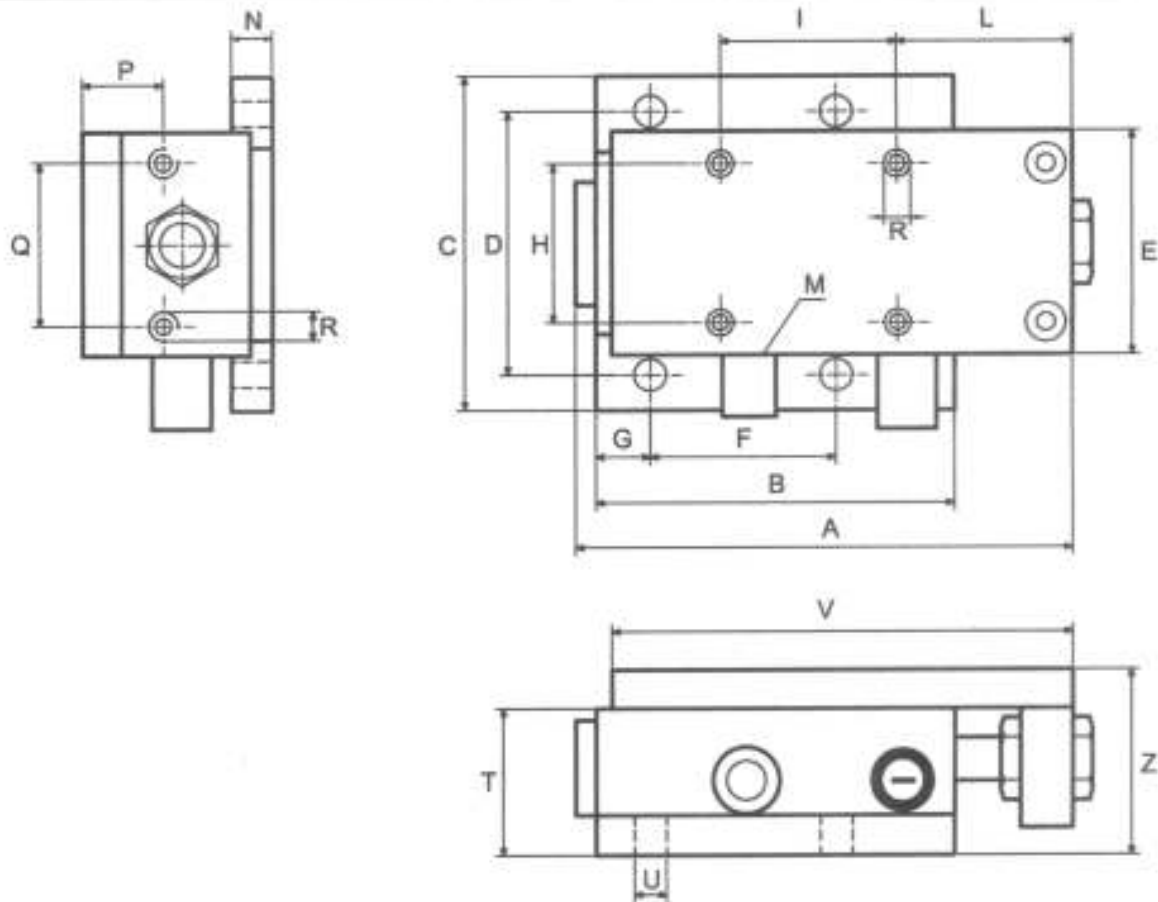

TYPE	POWER	WORKING PRESSURE (bar)	EVACUATING STROKE Max. mm.	MIN.MOUNTING INCLINATION	MAX LOAD (kg)
RE-1	Aria / air	2/6	25	5°	10
RE-2			25		25
RE-3			25		50
RE-4			25		750

MODEL	A	B	C	D	E	F	G	H	I	L	M	N	P	Q	R	T	U	V	Z
RE-1	140	95	90	70	60	49	14	25	40	40	1/8"	10	20	40	M6	38	9	120	48
RE-2	160	118	100	82	70	60	15	30	50	50	1/4"	12	25	50	M8	55	9	145	65
RE-3	160	118	122	104	90	60	15	40	60	60	1/4"	14	25	75	M8	78	9	145	88
RE-4	170	130	150	130	110	65	20	50	70	70	3/8"	18	30	80	M10	96	11	155	107