

EUROBOOR

LKF200 Beveling Machine

Welding edges from 15 ° - 60 ° steplessly variable

Welding edges from 0 to 20mm wide steplessly variable

Optimal protection

User friendly

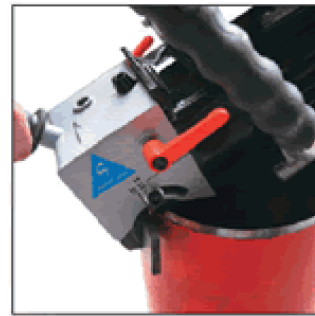

Mobile milling

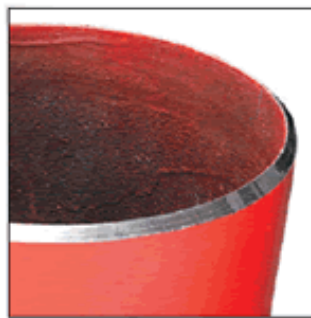

Perfect result



Thanks to the double roller guide the machine glides without problem over the material. With a weight of only 22 Kg the LKF200 is easily manageable. The milling angle is adjustable from 15° to 60° and the depth is steplessly variable and accurately adjustable. The LKF200 makes welding edges from 0 to 20 mm. The welding edges are perfectly formed and need no extra finishing. The LKF200 processes profiles, plates and pipes (from ø 160 mm) with the greatest of ease. The LKF200 is suitable for all metals. The motor is provided with an electronic overload safety and a re-start feature. The LKF200 is also provided with a compressed air connection that ensures extra cooling when used intensively.



Robust double milling head with 12 cutting plates



Safe and clear use



Variable angle adjustment from 15° - 60°

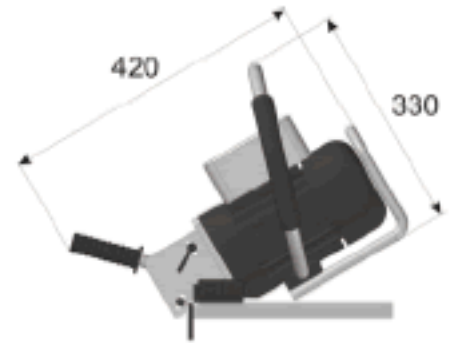

LKF.200

Voltage	110-120 and 220-240 V
Capacity	1100 Watt
Rotational Speed	2850 r.p.m.
Edge Angle	15° - 60°
Width of welding edge	0-20 mm
Dimensions LxBxH	420 x 300 x 300mm
Weight	22kg



Metal Form Group

Serviced and Supplied by:
 Metal Form Group
 1 Griffith St Knoxfield Vic 3180
 T 03 9763 8000
 F 03 9763 2335
 Email:sales@metalform.com.au

www.qualitycuttingtools.com.au